

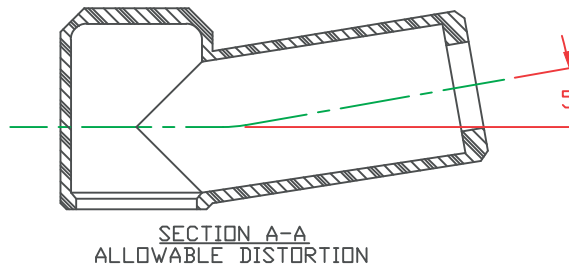

SECTION A-A
 TYP. WALL THICKNESS = .060" [1.5]
 TYP. BEVEL = 45°

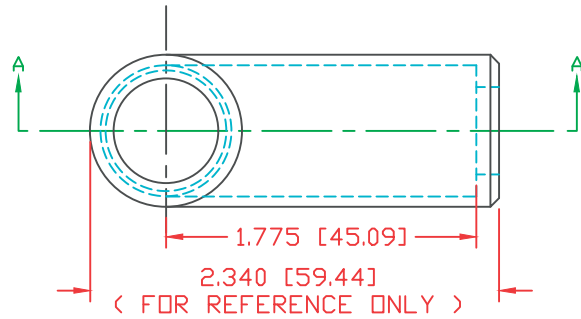

		PART NO.: 901915
3/8" STUD TERMINAL INSULATOR, 2-2/0 GA, RED (1 MIN)		
MATERIAL PART NO	1101650102	
MATERIAL	PVC	
VENDOR PART NO	9812-65-RED 683	
SHORE DUROMETER	"A" 10 SEC. 65	
SPECIFIC GRAVITY	1.34	
ULT. ELONGATION %	400	
MELTING TEMP	315-335° F [157-168° C]	
BRITTLE TEMP	-54° F [-48° C]	
TENSILE STRENGTH PSI	1550 PSI	
DIELECTRIC STRENGTH, V./MIL	511	
UL RATING	V2	
DIAGRAM NOT TO SCALE		